



National Network

Information, Guidance and
Training on the Americans with
Disabilities Act

Call us toll-free
1-800-949-4232 V/TTY
Find your regional center
at www.adata.org

For the most current and accessible version,
please visit <http://adainfo.us/ADAfood>

Food Service: Accommodating Diners with Disabilities

A variety of food service options are offered by restaurants, hotels, convention centers, banquet facilities, and other businesses. Making these services accessible for guests with disabilities makes good business sense. People with disabilities (not to mention the family members, friends, and colleagues who often accompany them) represent a large and growing market. Here are a few tips for business operators, event planners, and food service staff.

Room to Move

Path of travel: Check out the path of travel around self-serve stations, ordering and pick-up counters, and seating areas. Make sure there is enough clear space for people using wheelchairs, other mobility aids, or service animals, especially when chairs are pulled out and occupied.

Seating: Dining areas should include some accessible seating for wheelchair and scooter users dispersed throughout the available seating areas.

- Accessible table: table-top surface should be no higher than 34 inches above the floor and clear space underneath at least 27 inches high (for wheelchair users to get their feet and knees under the table).

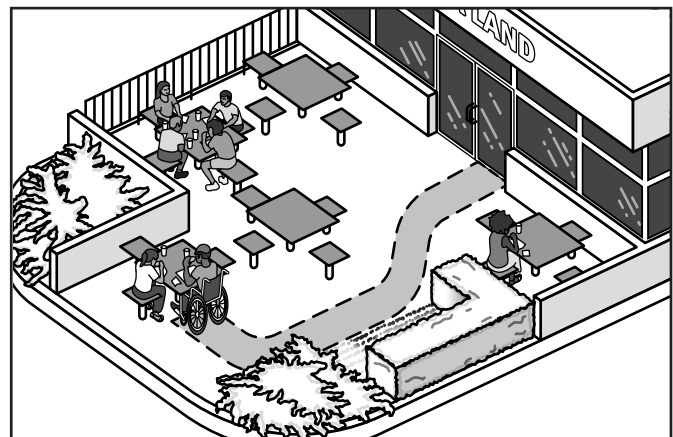

Temporary seating set up for special events should also include accessible tables. Chairs can be removed, where needed, to accommodate people who remain in their own wheelchairs or scooters for dining.

Mobility devices: Always ask the owner’s permission before moving a mobility device (crutches, walker, wheelchair or scooter) to an area that is safely out of the way of other patrons and servers.

- Think about seating options and convenient storage space for mobility devices.

Self-serve items: Here are some tips to provide easy use for people using wheelchairs or people of short stature.

- The tops of tables or counters for self-serve items should not be higher than 36 inches above the floor. Food service items are often placed toward the back of a table or counter or on risers or racks above the counter surface in order to leave space for people to set their trays, plates, or beverage containers. Unfortunately, this may make items more difficult to reach.
- Items that need to be seen and reached can be placed as high as 48 inches above the floor in some cases, but may need to be lower if they are farther from the front edge of the table or if room to approach is limited in other ways.

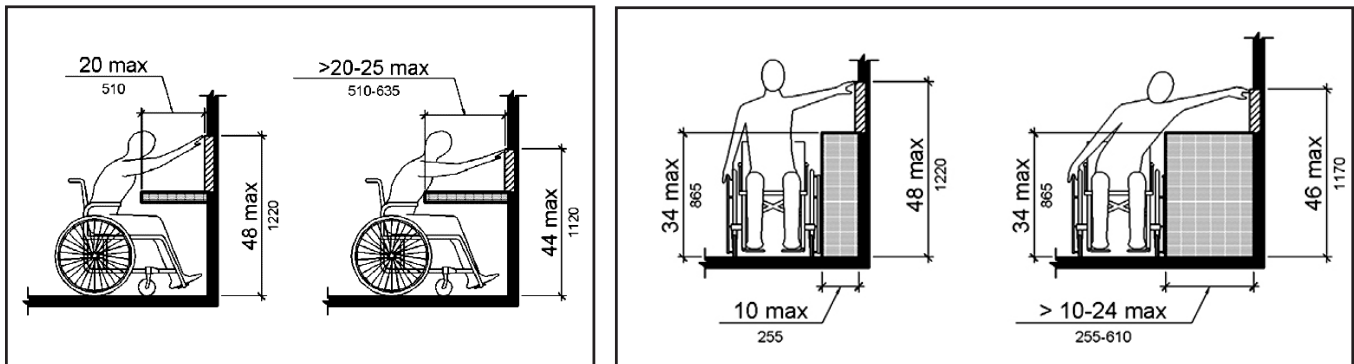

Image note: Reach range is listed first in inches and then in centimeters.

Take a seat: Pull up a chair and sit down next to the buffet or self-service area. If you can see and reach the items, they are probably accessible.

More Great Tips

Menus: When serving a buffet, place a menu at the beginning of the line to help guests with dietary restrictions or preferences make informed choices. This will help speed up the food line and cut down on waste. Menus and food labels should be large print, high contrast, and non-glare.

Offer straws: Some people with disabilities find it difficult to lift or hold glasses, cups, or other beverage containers. Providing straws, especially the type that bends, will be appreciated.

Offer assistance: People with a variety of disabilities, as well as older customers, may need assistance. Always ask first and wait for a response or direction from the individual.

- People who are blind or have low vision may need servers to read menus, assist with self-serve items, or provide directions to seating or restrooms.
- People who are deaf or hard of hearing may need to exchange notes or use other methods to communicate and get information about menu items.
- People who use service animals or have disabilities that affect strength, dexterity, or mobility may need assistance carrying trays or other self-serve items.
- Post signs offering assistance in self-serve areas.



Service Animals:

- People with disabilities may be accompanied by a service animal. Only dogs are recognized as service animals under Titles II and III of the ADA, and must be under control of the handler at all times.
- Generally, service animals may accompany people with disabilities in all areas where the public is normally allowed to go.
- Staff may ask two questions: 1. Is the dog a service animal required because of a disability; and 2. What work or task has the dog been trained to perform.

Content was developed by the Mid-Atlantic ADA Center, and is based on professional consensus of ADA experts and the ADA National Network.



<http://www.adainfo.org/>

The contents of this factsheet were developed under grants from the National Institute on Disability, Independent Living, and Rehabilitation Research (NIDILRR grant numbers 90DP0089 and 90DP0086). NIDILRR is a Center within the Administration for Community Living (ACL), Department of Health and Human Services (HHS). The contents of this factsheet do not necessarily represent the policy of NIDILRR, ACL, HHS, and you should not assume endorsement by the Federal Government.

© Copyright 2018 ADA National Network. All Rights Reserved.
May be reproduced and distributed freely with attribution to ADA National Network (www.adata.org).