



National Network

Information, Guidance and Training on
the Americans with Disabilities Act

Call us toll-free
1-800-949-4232 V/TTY

Find your regional
center at
www.adata.org

ADJUSTING DOORS FOR ACCESS

Doors present some of the most common accessibility issues. They may be too “heavy” and require too much force to open. Heavy doors are especially difficult for people with disabilities and seniors with limited upper body strength and/or skills in using their hands. They may close too quickly for some people to pass through easily. People who move slowly or use mobility devices like wheelchairs or walkers may not be able to pass through fast enough. Luckily, these common problems can often be resolved by simply adjusting door closers. Follow these steps to make sure your doors are accessible to all.

1. Measure Door Opening Force and Closing Speed

The best way to measure door opening force is by using a door force gauge, also called a door pressure gauge. To do this, first unlatch the door, then press the gauge against the door. Push until the door opens all the way. The readout on the gauge shows you the force required to open the door. Some gauges have hooks to help you pull

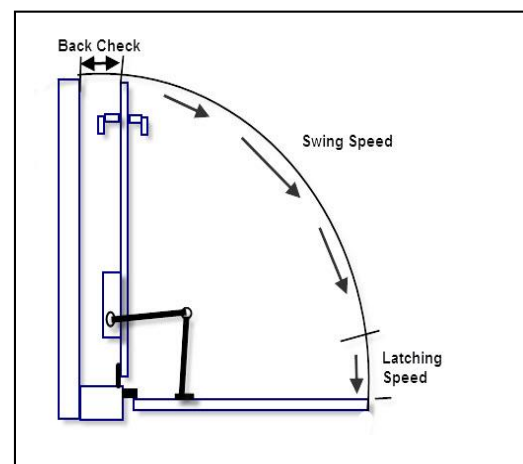



ADJUSTING DOORS FOR ACCESS

the door open. Door force gauges are available online and in some specialty hardware stores.

You may also use a simple mechanical or digital fish scale. These options may be less accurate since you have to read the scale while opening the door. To use a fish scale, attach a string to the scale and the door opening hardware. Measure the maximum force required to pull the door open.

Interior doors should require **no more than 5 lbs. of force** to open. This does not apply to the initial force needed to overcome the weight of a motionless door. Open the door gradually; do not “jerk” it open.

Opening force for exterior doors is not specified in the ADA Standards, but exterior doors that need to be accessible should have the minimum force possible. Typical maximum opening force for exterior doors ranges from 8.5 to 10 lbs. Any door so heavy that it prevents entrance by people with disabilities may deny them access to goods and services, which *is* covered under the ADA. Also, state or local government codes may have specific accessibility requirements for exterior doors.

The closing or swing speed must not be faster than five seconds. The closing or swing distance is from the open position at 90 degrees to 12 degrees from the latch. Latching speed isn't specified, but should be fast enough to latch the door but not slam it.

2. Determine the Simplest Solution

- ✓ Check to see if the problem is due to warping of the door or door frame, loose weather stripping or threshold, or door hinges that need tightening or lubricating.

- ✓ Check to see what type of closer is installed. Most closers are mounted at the top of a door or above it on the jamb. However, some doors use internal models hidden inside the door frame.

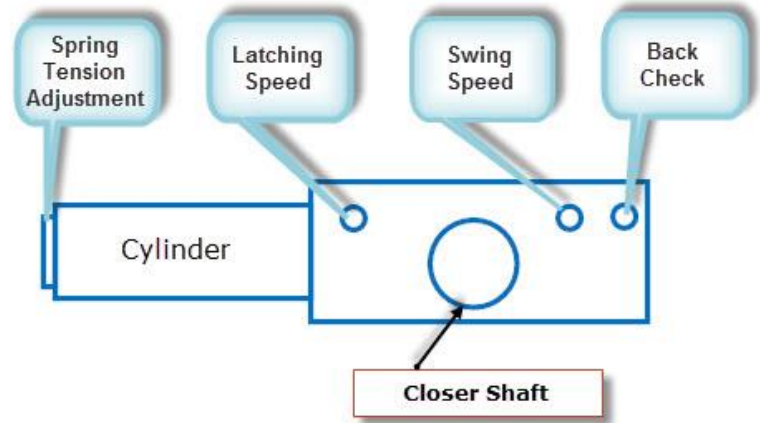

- Check to see if the closer is damaged or leaking oil.
- Check to see if the closer is still under warranty. Adjusting or repairing it may void or cancel your warranty.
- Decide whether to replace, adjust, or (in some extreme cases) remove the door closer.

Typical Symbols on a Closer

“S” - Swing Speed: adjustment for the long swing of the door.

“L” - Latch Speed: adjustment for the short final swing of the door.

“BC” - Back Check: adjustment to limit/slow the maximum swing of the

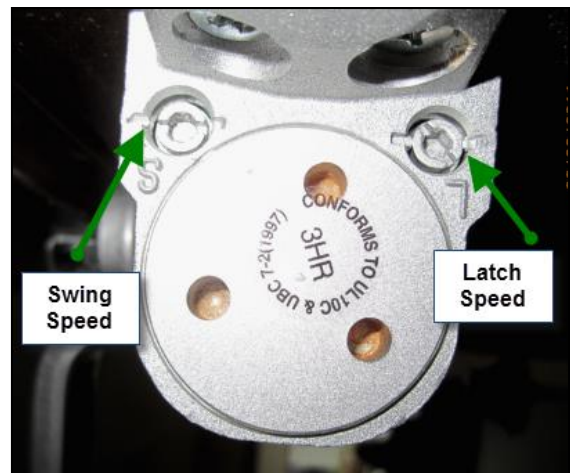

To adjust the latch or sweep speed:

Insert a 1/8-inch Allen wrench or screwdriver in the appropriate set screw. Turn it clockwise to reduce the speed, counterclockwise to increase the speed. The set screws are usually located on the end of the closer.

Be sure to refer to the closer’s maintenance manual before trying to make adjustments.

Ask building maintenance staff for help when possible.



ADJUSTING DOORS FOR ACCESS

Mechanical door closers use the hydraulic force provided by the user to shut the door after it is opened. Most closers allow you to adjust the speed and power of the door.

3. Make adjustments

To achieve the 5 lbs. maximum force required, you may need to experiment with the swing speed, spring tension,* and the foot or shoe adjustment.

***Spring tension does not usually need adjustment but can be increased to boost closing power.**

Foot or shoe adjustment:

In the standard position, the mounting hole is at the normal dimension. By rotating the foot or shoe, the adjustable arm can be offset to provide a large power increase. For closers with a two-hole shoe, you can move the adjustable arm closer to

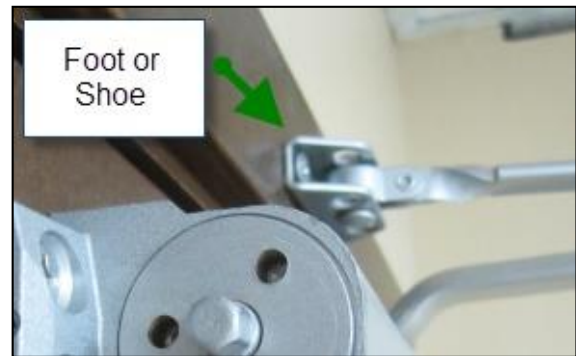

the hinge side of the door, increasing the power up to 15%. With a closer with a three-hole shoe, you can increase the power up to 7.5% by moving the arm from the center position to the hinge side of the door. Moving the arm from the center position to the latch side of the door can decrease the power as much as 7.5%.

For more information about accessibility requirements for doors (and facilities):

U.S. Department of Justice:

<http://www.ada.gov>

2010 ADA Standards:

http://www.ada.gov/2010ADASTandards_index.htm



ADJUSTING DOORS FOR ACCESS

U.S. Access Board:

www.access-board.gov

800-872-2253 (voice)

800-993-2822 (TTY)

Content was developed by the Northwest ADA Center, and is based on professional consensus of ADA experts and the ADA National Network.



For more information contact:

6912 220th St. SW, Suite 105

Mountlake Terrace, WA 98043

Toll-free: 800-949-4232

TTY: 800-949-4232

FAX: 425-774-9303

www.nwadacenter.org

This information product was developed under a grant from the Department of Education, NIDRR grant number H133A110014 and H133A110015. However, the contents do not necessarily represent the policy of the Department of Education, and you should not assume endorsement by the Federal Government.



© Copyright 2015 ADA National Network. All Rights Reserved.

May be reproduced and distributed freely with attribution to ADA National Network (www.adata.org).